



**STANDARD FEATURES**

- Dual ring cast iron burner
- Heavy duty cast iron grate
- Standby pilot for easy start
- Stainless steel adjustable heavy duty legs
- Zinc alloy knob with chrome coating
- Crumb tray at the bottom
- Easy conversion from natural gas to Propane or vice versa
- Stainless steel in the front and sides
- Available in single and double burners



**HDSSPR-1**

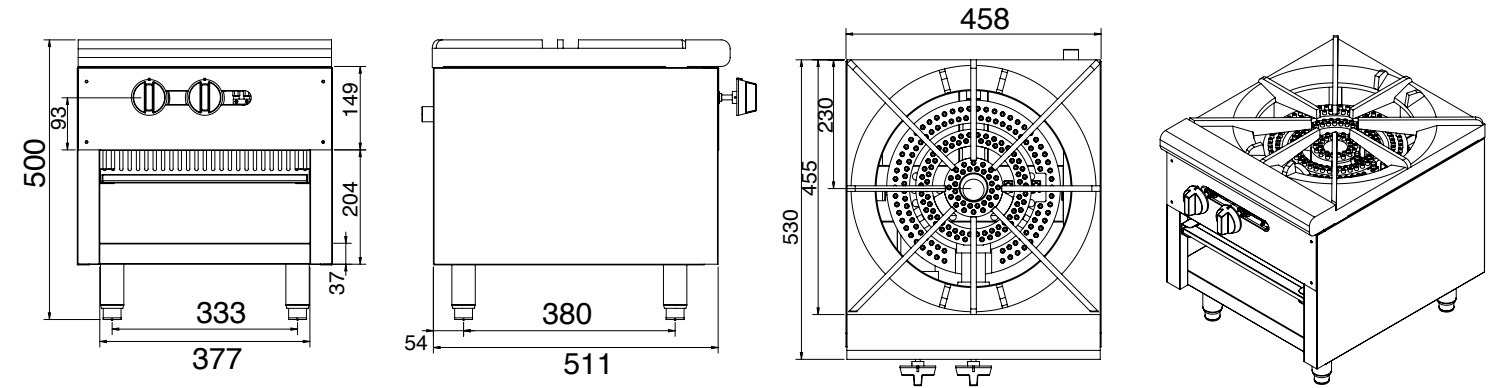

**HDSSPR-1**

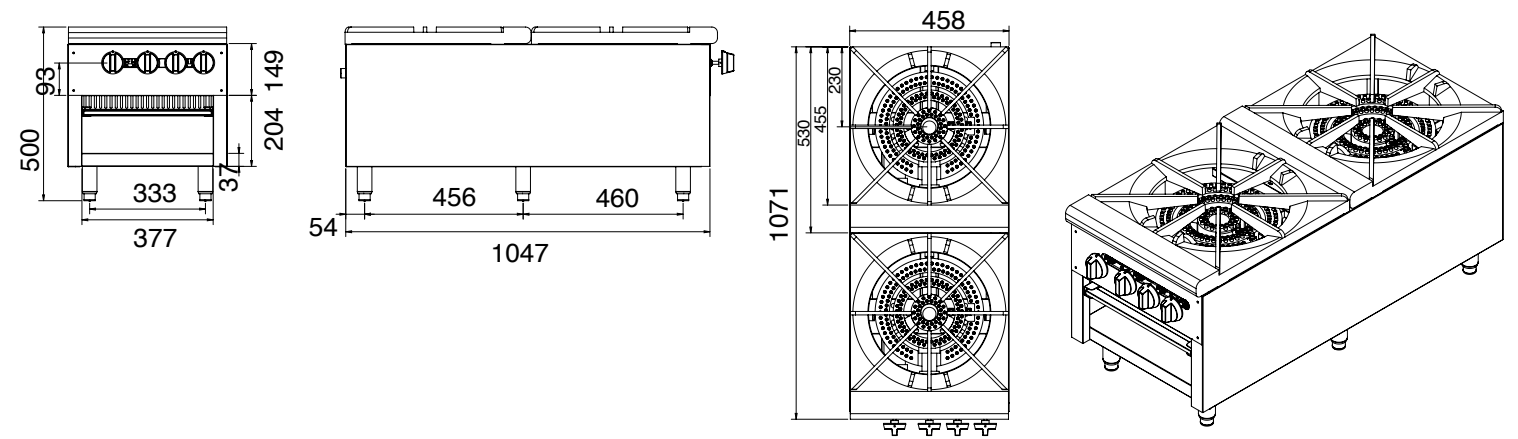

**HDSSPR-2**

- **Gas Products available in either Natural or LP Gas setup**
- **Thermostats (if applicable) available in either Fahrenheit or Celsius**

MODEL	DESCRIPTION	TOTAL INPUT (btu/hr)		PRODUCT (WxDxH)	PACKING (WxDxH)	NW	GW
		NATURAL GAS	PROPANE				
HDSSPR-1	Gas Stock Pot	80,000	50,000	456 x 530 x 493 mm 18 x 20.9 x 19.4 inch	610 x 770 x 508 mm 24 x 30.3 x 20 inch	47 kg 103 lbs	59 kg 130 lbs
HDSSPR-2	Gas Stock Pot	160,000	100,000	456 x 1050 x 493 mm 18 x 41.3 x 19.4 inch	610 x 1448 x 508 mm 24 x 57 x 20 inch	89 kg 196 lbs	100 kg 220 lbs

sales@heavydutysystems.com