

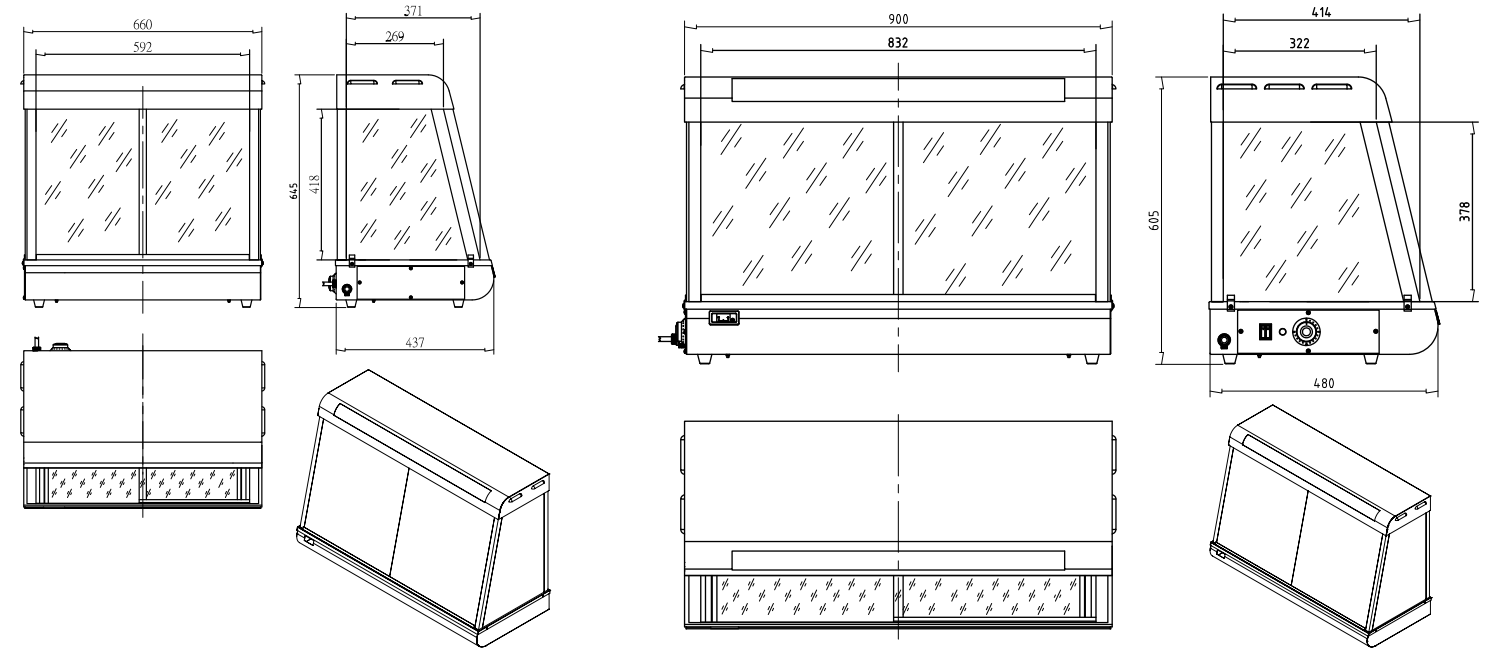

HDSHD-26

STANDARD FEATURES

- Toughened glass all sides
 - Thermostat controlled, durable and robust
 - Analogue temperature display
 - Temperature range 30-90°C (86-194° F)
 - Cool to touch Bakelite handle
 - Water reservoir at the bottom to add humidity when needed
 - Extra deep reservoir GN1/9 x 2.5" to last for whole day
 - (3) Adjustable shelves
 - Sliding doors
 - Rubber seal between door and frame to prevent heat loss
 - Vertical fluorescent lamp on both sides to better highlight food
 - Filament lamp on top for advertising posters to attract customer
 - On/off switch for lamps
 - Anti-slip rubber feet
 - Heating indicator
-
- **Thermostats (if applicable) available in either Fahrenheit or Celsius**
 - **Available in various electrical power setups (power setups available for all areas of the world)**
 - **Power may vary based on specified electrical setup**



HDSHD-26

HDSHD-36

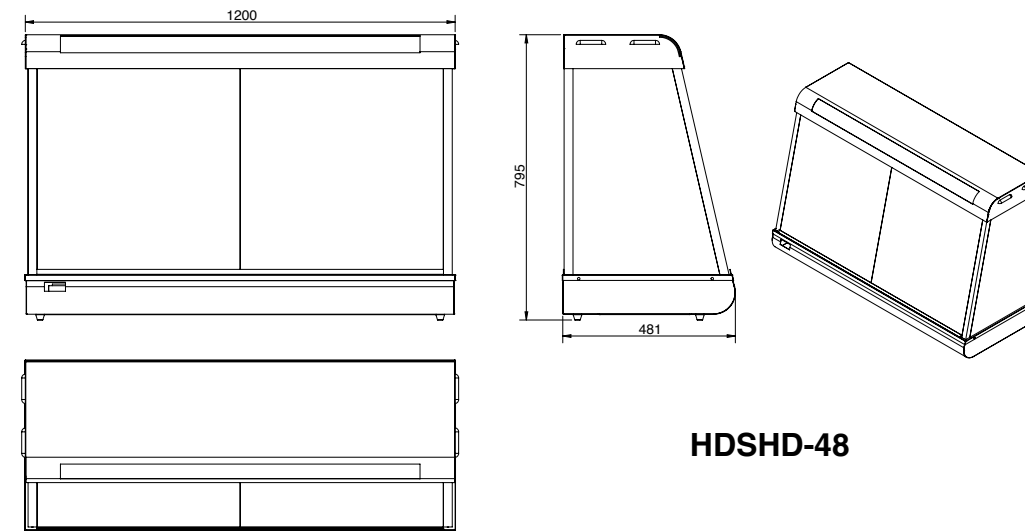

HDSHD-48

MODEL	CAPACITY	POWER	SHELF SIZE	PRODUCT (WxDxH)	NW
HDSHD-26	110 L	1840 W	580 x 275 mm / 23 x 11 inch 580 x 298 mm / 23 x 12 inch 580 x 318 mm / 23 x 13 inch	660 x 437 x 655 mm 26 x 17 x 26 inch	35 kg 77 lbs
HDSHD-36	150 L	1840 W	820 x 315 mm / 32 x 12 inch 820 x 340 mm / 32 x 13 inch 820 x 360 mm / 32 x 14 inch	900 x 480 x 590 mm 35 x 19 x 23 inch	50 kg 110 lbs
HDSHD-48	370 L	2200 W	1120 x 315 mm / 44 x 12 inch 1120 x 340 mm / 44 x 13 inch 1120 x 360 mm / 44 x 14 inch	1200 x 480 x 810 mm 47 x 19 x 32 inch	72 kg 158 lbs

sales@heavydutysystems.com